



UNIVERSITY OF CAMBRIDGE INTERNATIONAL EXAMINATIONS  
General Certificate of Education Ordinary Level

CANDIDATE  
NAME

CENTRE  
NUMBER

--	--	--	--	--

CANDIDATE  
NUMBER

--	--	--	--



**COMBINED SCIENCE**

**5129/22**

Paper 2

**May/June 2013**

**2 hours 15 minutes**

Candidates answer on the Question Paper.

No Additional Materials are required.

**READ THESE INSTRUCTIONS FIRST**

Write your Centre number, candidate number and name on all the work you hand in.

Write in dark blue or black pen.

You may use a soft pencil for any diagrams, graphs or rough working.

Do not use staples, paper clips, highlighters, glue or correction fluid.

**DO NOT WRITE IN ANY BARCODES.**

Answer **all** questions.

Electronic calculators may be used.

You may lose marks if you do not show your working or if you do not use appropriate units.

A copy of the Periodic Table is printed on page 20.

Electronic calculators may be used.

You may lose marks if you do not use appropriate units.

At the end of the examination, fasten all your work securely together.

The number of marks is given in brackets [ ] at the end of each question or part question.

This document consists of **20** printed pages.



1 Use words from the list to complete the sentences below.

carbon                      carbon dioxide                      chemical                      chlorophyll  
haemoglobin                      heat                      hormones                      light  
nitrogen                      oxygen                      phloem

Each word may be used once, more than once or not at all.

(a) Energy from the Sun is converted into ..... energy during photosynthesis. This energy is trapped by ..... and used to combine water and ..... to form glucose. [3]

(b) Ions containing ..... are needed for a plant to form proteins. [1]

2 (a) Magnesium reacts with nitrogen to produce magnesium nitride. The equation for the reaction is



The relative molecular mass,  $M_r$ , of magnesium nitride is 100.

[ $A_r$ : Mg, 24; N, 14]

Complete the following sentences.

144 g of magnesium reacts with .....g of nitrogen and produces

.....g of magnesium nitride.

14.4 g of magnesium reacts with .....g of nitrogen and produces

.....g of magnesium nitride.

2.4 g of magnesium produces .....g of magnesium nitride.

[4]

(b) Explain why the bonding in magnesium nitride is ionic.

.....

..... [1]

- (c) Nitrogen and oxygen are the major constituents of air.  
State the percentages of nitrogen and of oxygen in the air.

nitrogen .....

oxygen .....

[1]

- 3 Fig. 3.1 shows a measuring cylinder containing a liquid.

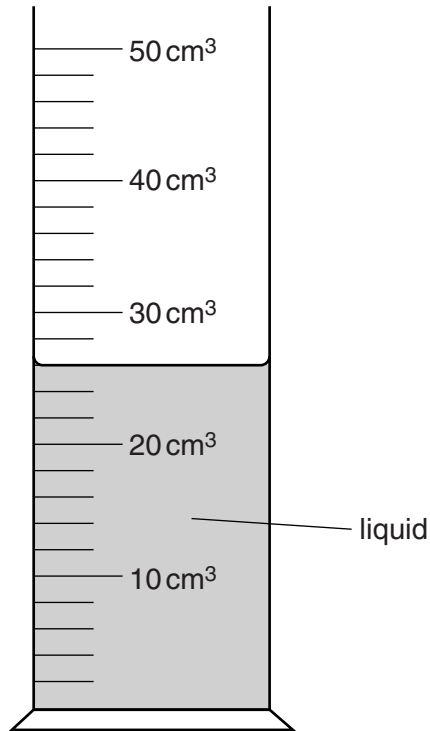

Fig. 3.1

- (a) State the volume of the liquid in the cylinder.

volume = ..... cm<sup>3</sup> [1]

- (b) The mass of the measuring cylinder and the liquid is 30.2g.

The mass of the empty measuring cylinder is 9.4g.

Calculate the density of the liquid.

density = ..... units ..... [3]

4 Fig. 4.1 shows how the speed of a runner changes with time.

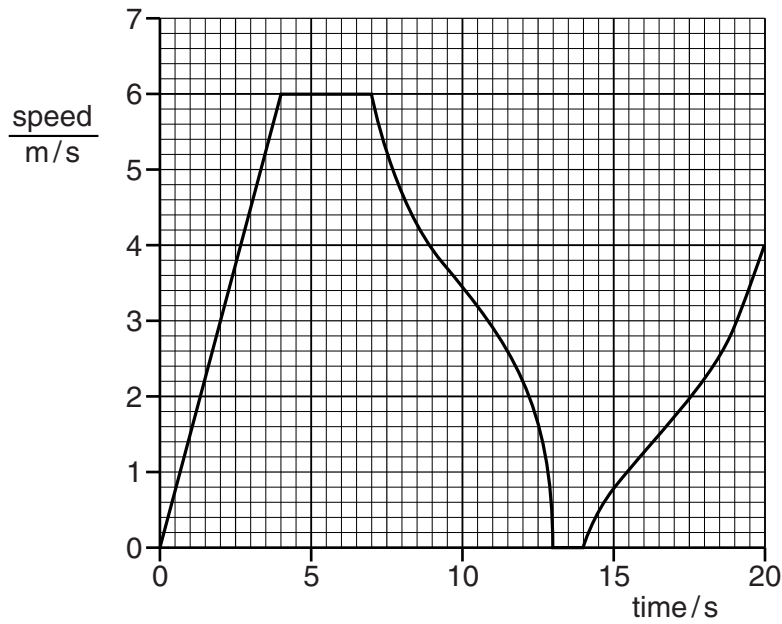

Fig. 4.1

(a) Use Fig. 4.1 to calculate the length of time that the runner is

- (i) at rest, .....s
- (ii) moving with constant non-zero acceleration. ....s

[2]

(b) Explain why it is possible for the runner to have a constant speed but not have a constant velocity.

.....  
 ..... [1]

(c) The runner has a mass of 70.0 kg.

At one time, the accelerating force produced by the runner is 175 N.

Calculate the acceleration of the runner.

acceleration = ..... m/s<sup>2</sup> [2]

5 Fig. 5.1 shows cell functions and different types of cell.

On Fig. 5.1, draw a line to link each cell function with the type of cell that carries out that function.

One line has been drawn for you.

Each type of cell may be linked-to once, more than once, or not at all.

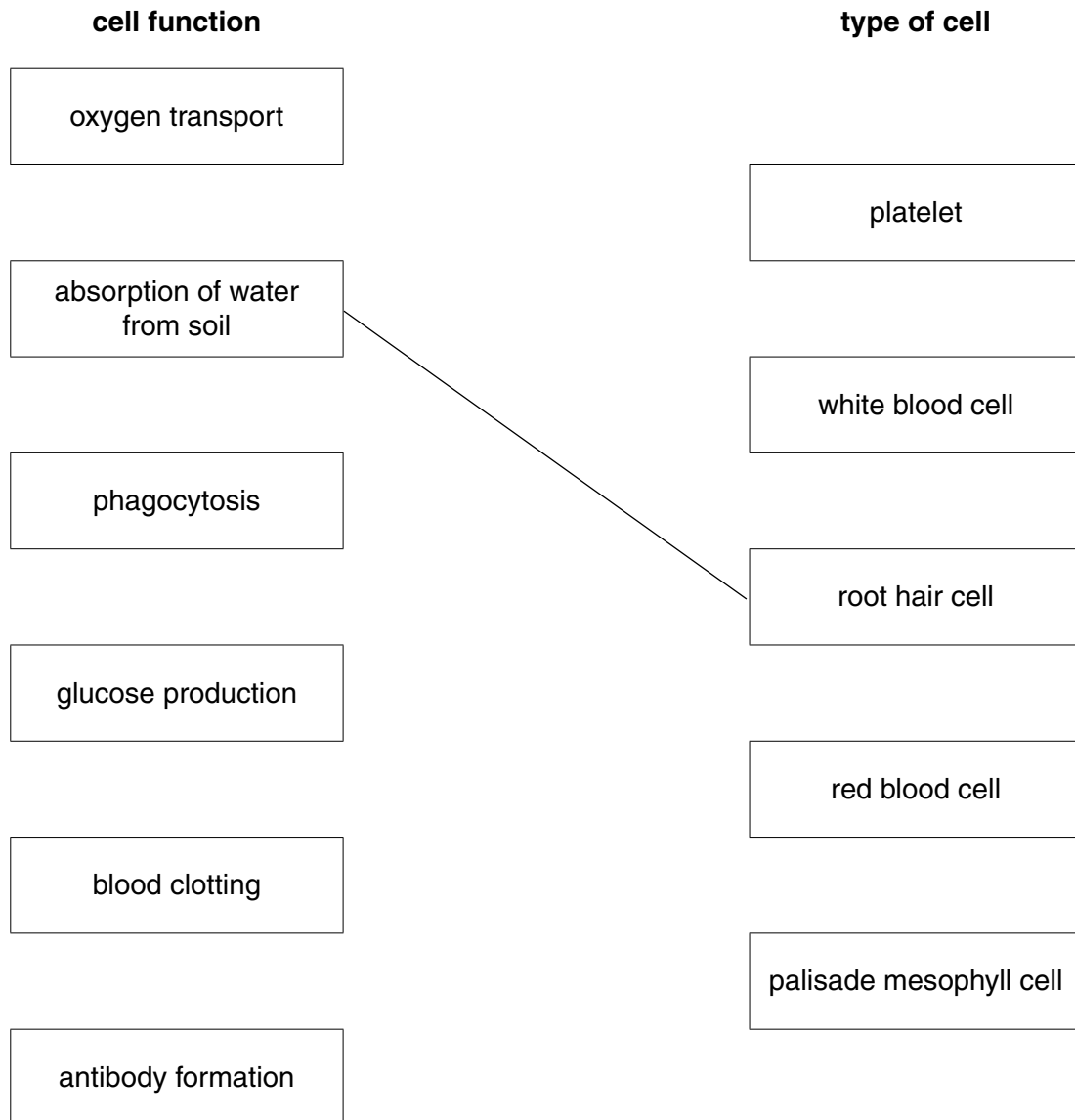

Fig. 5.1

[5]

6 Element **P** reacts with dilute hydrochloric acid but not with steam.

Element **Q** does **not** react with dilute hydrochloric acid.

Element **R** reacts with both dilute hydrochloric acid and cold water.

Element **S** reacts with both dilute hydrochloric acid and steam but not cold water.

(a) Deduce the order of reactivity of the elements **P**, **Q**, **R** and **S**.

most reactive .....

.....

.....

least reactive .....

[2]

(b) When element **S** reacts with dilute hydrochloric acid, hydrogen is given off and a solution of the chloride of **S** is produced.

(i) State the test for hydrogen.

test .....

result .....

..... [2]

(ii) Element **S** forms an ion **S<sup>2+</sup>**.

Deduce the formula of the chloride of **S**. ..... [1]

(c) One of the four elements **P**, **Q**, **R** and **S** is zinc.

Complete the equation for the reaction of zinc with steam.



7 A weight-lifter lifts a weight of 1700N.

(a) Calculate the work done on the weight in lifting it through a vertical distance of 2.0m.

work done = ..... J [2]

(b) Complete the following sentence.

As the weight is being lifted, the useful energy changes are from  
..... energy of the weight-lifter to .....  
energy and ..... energy of the weight. [2]

8 Sound is an example of a longitudinal wave.

Air particles vibrate as the sound wave passes through the air.

(a) Fig. 8.1 shows the direction of vibration of an air particle as a sound wave moves through the air.

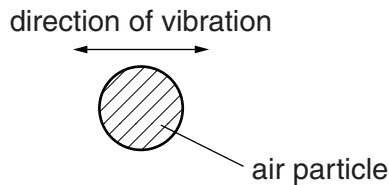

Fig. 8.1

On Fig. 8.1, draw an arrow to show a possible direction of the sound wave. [1]

(b) (i) Explain what is meant by *frequency*.

.....  
..... [1]

(ii) A sound wave has a frequency of 200Hz and travels at a speed of 340m/s.

Calculate the wavelength of the sound wave.

wavelength = ..... m [2]

9 Amylase is an enzyme that digests starch.

(a) State the chemical produced when amylase digests starch.

..... [1]

Iodine solution is a brown liquid. When starch and iodine solution are mixed together, the starch grains are stained black.

An experiment used to investigate amylase digesting starch is shown in Fig. 9.1.

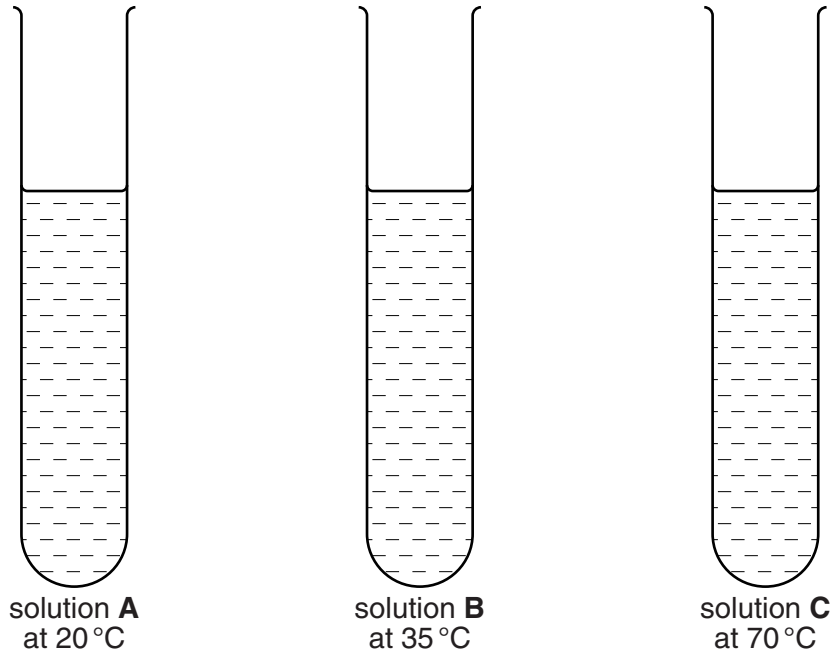

**Fig. 9.1**

Each tube contains the same concentrations of starch, amylase and iodine solution.

Each tube is kept at a different temperature, as shown in Fig. 9.1.

Table 9.1 shows the results of this experiment.

**Table 9.1**

time/min	colour of solution		
	solution A	solution B	solution C
1	black	black	black
15	black	brown	black
25	brown	brown	black



(b) Explain why solutions **A** and **B** change from black to brown.

.....  
.....  
.....  
..... [2]

(c) (i) State which solution turns brown most quickly.

..... [1]

(ii) Explain the difference in the timing of the colour change in solutions **A** and **B**.

.....  
.....  
.....  
..... [2]

(iii) Explain why solution **C** remains black.

.....  
.....  
.....  
..... [2]

10 Fig. 10.1 shows some reactions of ethene.

For  
Examiner's  
Use

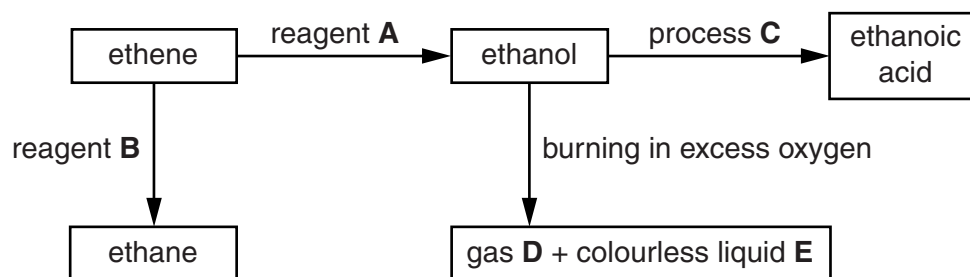

Fig. 10.1

(a) (i) Identify the reagents **A** and **B** and process **C**.

reagent **A** .....

reagent **B** .....

process **C** .....

[3]

(ii) Identify gas **D** and liquid **E**.

gas **D** .....

liquid **E** .....

[2]

(b) The molecular formula of ethanol is  $C_2H_5OH$ .

(i) Draw the structure of ethanol.

[1]

(ii) State one use of ethanol.

..... [1]

11 Fig. 11.1 shows a lighting circuit.

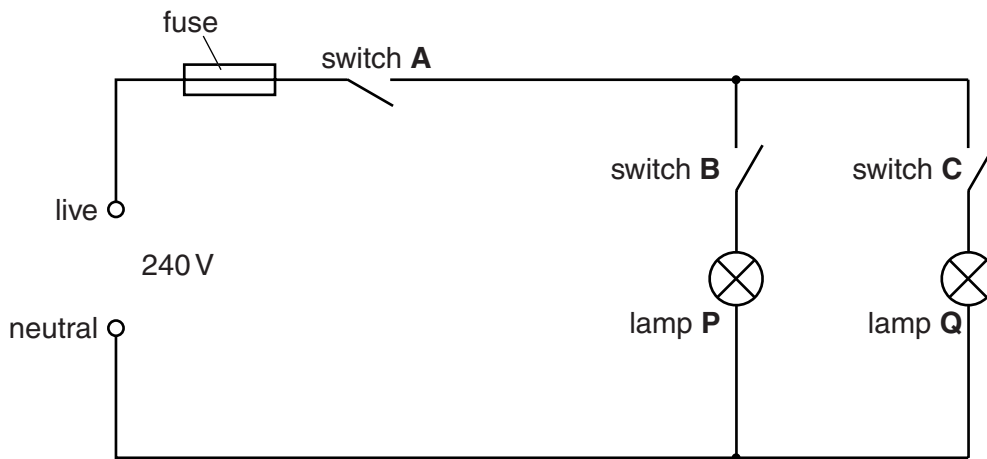

Fig. 11.1

(a) Switch **A** is left open and switches **B** and **C** are closed.

State which lamp or lamps, if any, will light. .... [1]

(b) The circuit contains a fuse.

The fuse has a rating of 3A.

Explain what is meant by the *fuse rating*.

.....  
..... [2]

(c) When all the switches are closed to light both lamps, the current in lamp **P** is 0.25A and the current in lamp **Q** is 0.35A.

(i) Calculate the current in the fuse.

current = ..... A [1]

(ii) The p.d. across lamp **P** when lit is 240V and the current in it is 0.25A.

Calculate the power of lamp **P**.

power = ..... W [2]

- 12 Fig. 12.1 shows an electromagnet, an iron rod and a permanent magnet. The poles of the permanent magnet are marked.

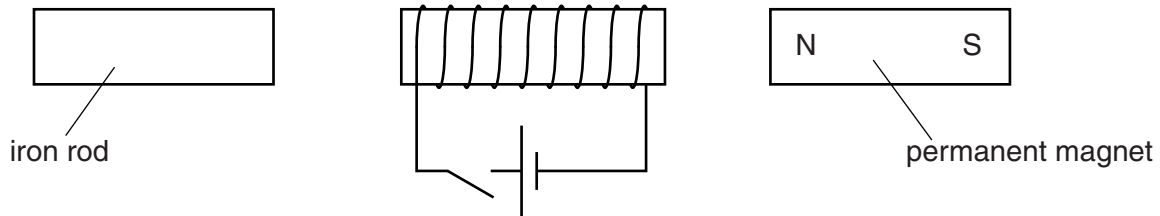

Fig. 12.1

- (a) The current in the electromagnet is switched on and the iron rod becomes magnetised. Both the iron rod and the permanent magnet are attracted to the electromagnet.

On Fig. 12.1, mark the poles of the iron rod.

[1]

- (b) The current in the electromagnet is now reversed.

- (i) State whether the iron rod is attracted, repelled or neither attracted nor repelled.

The iron rod is .....

- (ii) State whether the permanent magnet is attracted, repelled or neither attracted nor repelled.

The permanent magnet is .....

[2]

13 (a) Complete Table 13.1.

For  
Examiner's  
Use

particle	number of protons	number of neutrons	number of electrons
$^{16}\text{O}$	8		8
$^{27}\text{Al}$		14	13
$^{35}\text{Cl}^-$		18	18
$^{40}\text{Ca}^{2+}$	20	20	

[4]

Table 13.1

(b) Complete Fig. 13.1 to show the electronic structure of  $^{16}\text{O}$ .

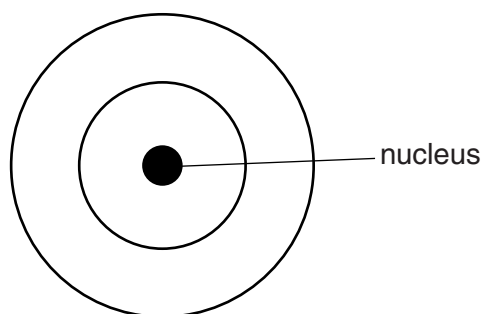

Fig. 13.1

[1]

14 Fig. 14.1 shows a flower.

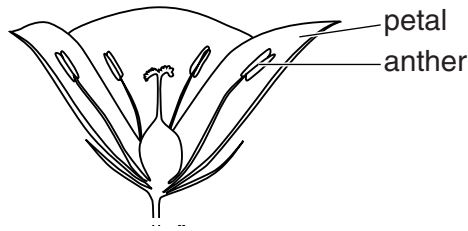

Fig. 14.1

(a) (i) State the function of petals.

.....  
 ..... [1]

(ii) State the function of anthers.

.....  
 ..... [1]

(b) Fig. 14.2 shows a section through a seed.

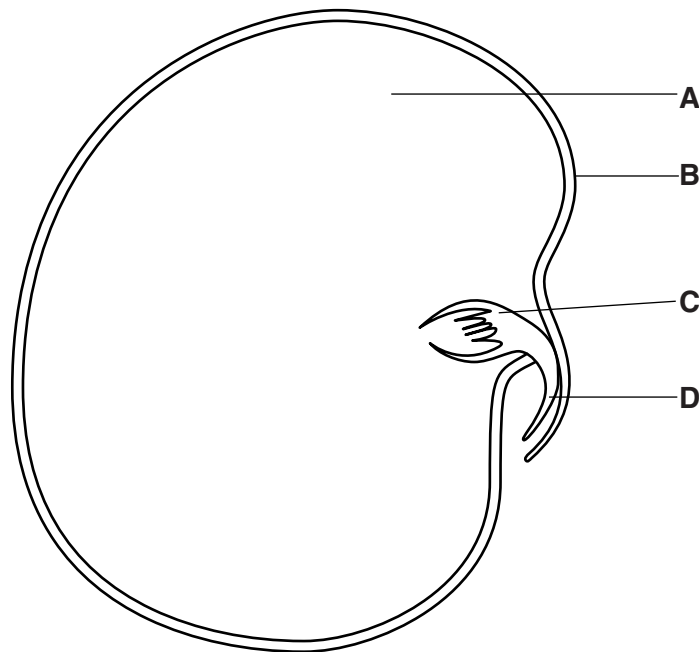

Fig. 14.2

(i) Use letters from the diagram to identify

1. the testa, .....
2. the radicle. ....

[2]

(ii) State a function of the cotyledon.

.....  
 ..... [1]

(c) (i) State two ways in which seeds are dispersed.

1. ....  
 .....  
 2. ....  
 .....

[2]

(ii) Explain why it is important for seeds to be dispersed.

.....  
 .....

[1]

(d) Complete Table 14.1 to show differences between asexual reproduction and sexual reproduction for the given features.

**Table 14.1**

feature	asexual reproduction	sexual reproduction
number of parents		
appearance of offspring		

[2]

15 Fig. 15.1 shows a heater emitting infra-red radiation.

For  
Examiner's  
Use

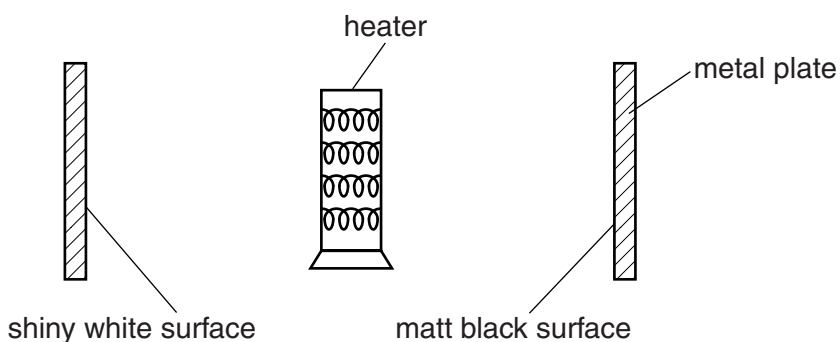

Fig. 15.1

Two metal plates are placed equal distances from the heater.

One plate has a shiny white surface and the other plate has a matt black surface.

(a) There is a large air-gap between each plate and the heater.

Suggest why there is very little heating of the plates by

(i) conduction, .....  
..... [1]

(ii) convection. ....  
..... [1]

(b) Explain why the plate with the matt black surface heats up more quickly than the plate with the shiny white surface.

.....  
..... [1]

(c) Infra-red radiation is part of the electromagnetic spectrum.

Name two components of the electromagnetic spectrum with longer wavelengths than infra-red radiation.

1. ....  
2. ....  
[2]



16 The following is a list of metals.

**copper**

**iron**

**lead**

**sodium**

**zinc**

For  
Examiner's  
Use

Each word in the list may be used once, more than once, or not at all.

From the list, select the metal that

(a) (i) is extracted from haematite,

.....

(ii) is used for electrical wiring,

.....

(iii) forms compounds which pollute the air,

.....

(iv) is used in galvanising.

.....

[4]

(b) Brass is an alloy.

(i) State what is meant by the term *alloy*.

..... [1]

(ii) Explain why metals are made into alloys.

.....

..... [1]

17 Fig. 17.1 shows a magnet being pushed towards a coil to induce an e.m.f.

For  
Examiner's  
Use

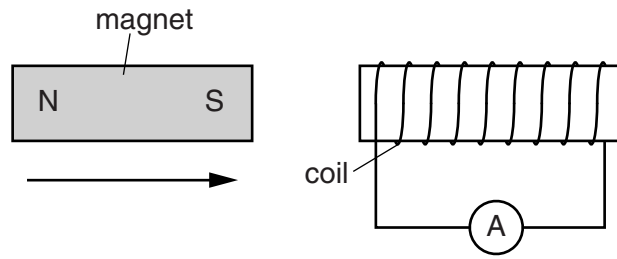

Fig. 17.1

A current is induced in the coil.

Explain how the induced current produces effects that oppose the motion of the magnet.

.....

.....

..... [2]

18 (a) Define a *drug*.

.....

.....

.....

..... [2]

(b) (i) Alcohol is a drug.

State **three** effects that the excessive consumption of alcohol may have on a person.

1. ....

.....

2. ....

.....

3. ....

.....

[3]

(ii) Name a drug of abuse other than alcohol.

..... [1]

19 A student breaks a bottle containing potassium nitrate crystals.

In order to separate the potassium nitrate from the broken glass, the student adds the mixture to water.

Use words from the list below to complete the following sentences.

Each word may be used once, more than once, or not at all.

**distillation      filtration      insoluble      soluble**  
**solute                  solution                  solvent**

The potassium nitrate dissolves in the water to form a colourless .....

The glass is ..... in water and is removed from the solution by

..... . In this experiment the potassium nitrate acts as the

.....

[4]

Permission to reproduce items where third-party owned material protected by copyright is included has been sought and cleared where possible. Every reasonable effort has been made by the publisher (UCLES) to trace copyright holders, but if any items requiring clearance have unwittingly been included, the publisher will be pleased to make amends at the earliest possible opportunity.

University of Cambridge International Examinations is part of the Cambridge Assessment Group. Cambridge Assessment is the brand name of University of Cambridge Local Examinations Syndicate (UCLES), which is itself a department of the University of Cambridge.

